

# RESTORE™ WALK-IN TUB

## FEATURES

- 51 ½" x 30" x 40" Walk-in Tub
- Taller than standard tub with sculpted 17" high seat (ADA), allows the bather to remain in an upright position while being completely submerged in water
- Water-tight, inward swinging door with Lifetime Guarantee on the seal gives users with limited mobility a safe and easy entry and exit
- Non-rusting door hinge and handle
- Easy door locking system
- Available in white
- Rich, high gloss finish and slip resistant floor
- Adjustable one-inch steel frame with adjustable feet
- Replaces standard size tub with right or left hand drain and fits through a standard 32" bathroom doorway
- Removable access panels allow for complete access to components
- Available in Soaker, Whirlpool, Air Bath and Combinations in both left and right hand drain options
- Outstanding Protection - 10 year warranty on shell, 5 year warranty on all factory installed components



## MODELS

MODEL #	DESCRIPTION	APPROX. WT.
<b>8010</b>	Whirlpool - Right Hand	225 lbs.
<b>8110</b>	Whirlpool - Left Hand	225 lbs.
<b>8210</b>	Bathtub - Right Hand	195 lbs.
<b>8310</b>	Bathtub - Left Hand	195 lbs.
<b>8410</b>	Air Bath - Right Hand	215 lbs.
<b>8510</b>	Air Bath - Left Hand	215 lbs.
<b>8610</b>	Combination - Right Hand	255 lbs.
<b>8710</b>	Combination - Left Hand	255 lbs.

## FEATURES & OPTIONS

### SOAKING TUB

- Tall, standard tub equipped with a water-tight door that allows you to enter effortlessly
- Cable waste and overflow standard feature

### AIR BATH

- 16 strategically placed air jets with check valves
- Hygienic purge feature - begins the drying process
- Raised air button easily turns blower on and off
- 120V, 8 amp, blower with heating element
- Cable waste and overflow standard feature

### WHIRLPOOL

- 5 multi-directional hydrotherapy jets, each with individual volume control
- Inline heater to maintain warm water temperature
- Electronic, color coded keypad for easy operation
- 120V, 9 amp pump
- Cable waste and overflow standard feature

### COMBINATION BATH

- Combines the air and whirlpool jets in a single bath for the best of both worlds

# RESTORE™ WALK-IN TUB

## SPECIFICATIONS

<b>DIMENSIONS</b>	51 ½' x 30' x 40'	<b>ELECTRICAL REQUIREMENTS</b>	<b>Air Bath:</b> One dedicated, 120V, 20 amp GFCI protected circuit. <b>Whirlpool:</b> Two separate, dedicated, 120V, 20 amp GFCI protected circuits. <b>Combination:</b> Three separate dedicated, 120V, 20 amp GFCI protected circuits.
<b>MATERIAL</b>	Marine Grade Fiberglass		
<b>CONSTRUCTION</b>	Outer finish is a double hand applied gelcoat. Frame is one inch powder-coated steel. All hardware and door mechanisms are finest quality stainless steel.		
<b>PUMP MOTOR</b>	Whirlpool: 120V, 9 amp	<b>NUMBER OF JETS</b>	Whirlpool: 5 jets Air Bath: 16 jet holes
<b>AIR BLOWER</b>	Air bath: 120V, 8 amp	<b>WATER CAPACITY:</b>	40 - 50 gallons (with bather)
<b>INCLUDES</b>	Wall bracket kit, end panel, front panel and cable drain. Nailing flange kit, additional end panel and extension box optional.	<b>FLOOR LOADING:</b>	450 lbs.
		<b>WARRANTY:</b>	10 - Year warranty on the shell 5 - Year warranty on factory components Lifetime warranty on the door seal

## TECHNICAL INFORMATION

**Note:** Product is manufactured to comply with industry standards. Rough-in dimensions may vary +/- ¼".

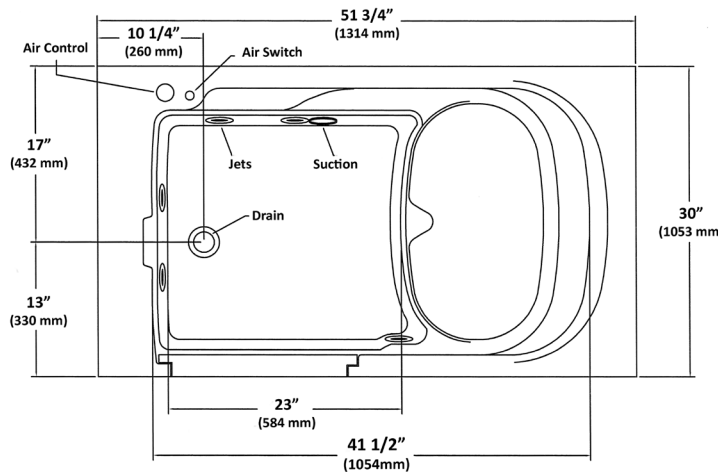

**RESTORE LH (LEFT HAND DRAIN)**

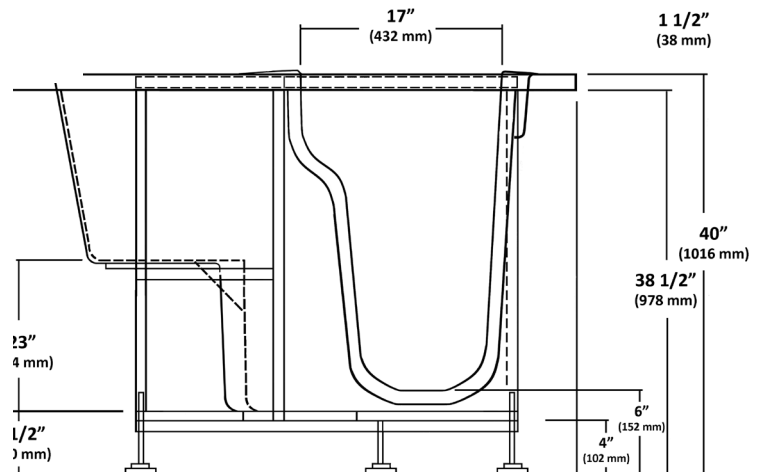

**RESTORE RH (RIGHT HAND DRAIN)**