

PRO-FIT® WHIRLPOOL & BATHTUB

3672 TFS 72" x 36" x 21 1/2"

Model number: 6122/6622 RH, 6123/6623 LH

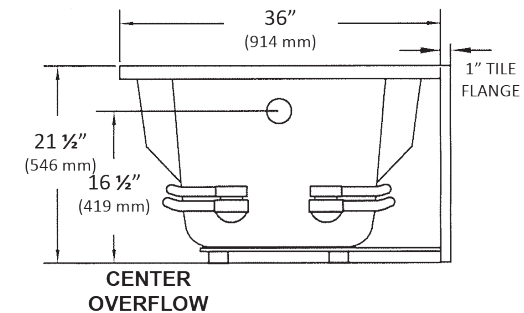
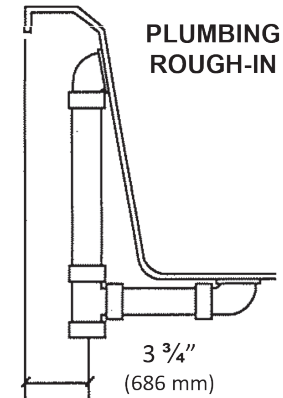
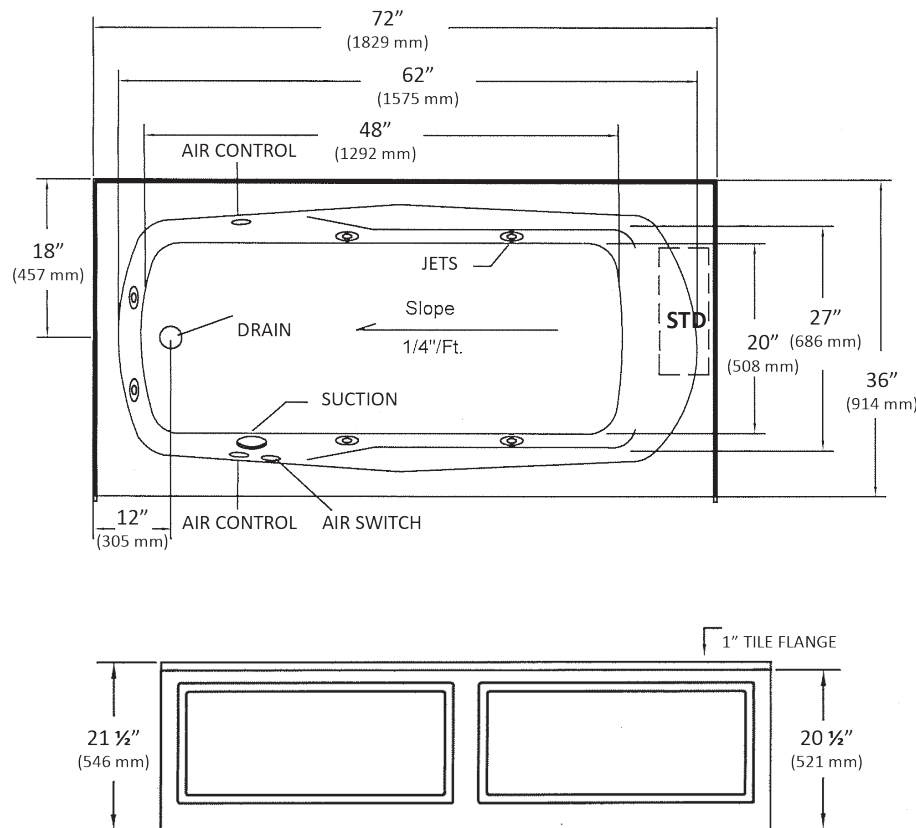

NOTES:

1. Pump location shown for clarity.
2. Required pump motor access is 20" W x 15" H.
3. Measurements may vary 1/4" (+/-).
4. Apron is integral with optional removable access panels.
5. Removable access panel provides access to blower/motor.
6. Specify LH or RH drain when ordering.

SPECIFICATIONS:

Dimensions:	72" x 36" x 21 1/2"	Number of jets:	6
Material:	Acrylic, fiberglass reinforced	Weight:	125 lbs.
Pump Motor:	120 V, 60 HZ, 6.0 Amp, Single Speed, Premounted	Water Capacity:	52 gals max., 38 gals min.
Electrical Requirements:	120 V, 15 Amp, GFCI Protected	Floor Loading:	47 lbs./sq.ft.
On/Off Control:	Air Switch	Shipping Weight:	155 lbs.