

# CP-1312 Commercial Package

1312 bowl, flush valve, toilet seat and wax ring



## Bowl Features

- Designed for commercial and industrial applications
- Elongated, floor mount, rear outlet
- 1.28 or 1.6 gpf low water consumption (1.28 when using the included flushometer)
- High performance, high efficiency (HET)
- 1-3/4" glazed trapway
- The Mansfield® limited lifetime warranty
- Available in White

## Valve Features

- Manual toilet flush valve for floor-mounted or wall-hung top spud bowls
- Chrome-plated housing
- Fits right or left hand supply
- Durable diaphragm with filtered fixed by-pass
- Chloramine resistant diaphragm
- ADA compliant metal non-hold-open handle with sealed handle package
- Vandal resistant torqued stop cap
- High back pressure vacuum break flush connection
- Spud coupling and flange for 1-1/2" top spud
- Chrome-plated copper casting resistant to dezincification
- 1" I.P.S. anglestop



Elongated Front



Model CP-1312

## Components

### CP-1312-128

1312	Rear Outlet Elongated front toilet bowl
FM-T2	Flushometer Valve for 1.28 Gpf toilet
SB900	Commercial elongated toilet seat
—	Wax ring

## Specifications

### BOWL

Model #	Description	Codes/Standards
1312	Floor mount, elongated front, flush valve 1.28 or 1.6 Gpf toilet (when using the proper flushometer)	<b>HET</b> HIGH EFFICIENCY TOILET

Specification	Description	Specification	Description
Material	Vitreous China	Trap Diameter	1-3/4"
Water Pressure Range	20 to 80 PSI	Trap Seal	2-5/8"
Water Usage	1.28 or 1.6 Gpf / 4.86 or 6.0 Lpf	Rough-in	Rear Outlet
Water Surface Area	10-1/4" x 12-1/4"	Shipping Weight	Model 1312 - 61 lbs. (28 kg)
MaP Rating	1,000 grams	Warranty	Vitreous China - Limited Lifetime Tank Trim - Limited One Year

### VALVE

Specification	Description	Specification	Description
Material	Brass Casting	Backflow Prevention	vacuum breaker/check valve
Plating	Chrome per ASTM B456	Water Type	potable cold water
Water Delivered	1.28	Shipping Weight	7.15 lbs.
Water Pressure Range	20 to 125 psi	Warranty	Limited Three Years

## Technical Information

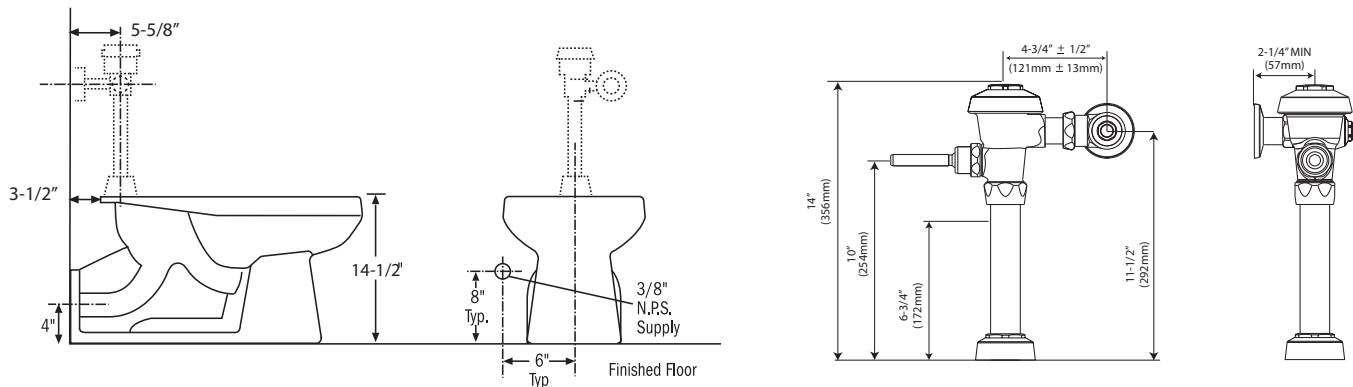

See our complete line of acrylic and vitreous china bathroom fixtures, plastic tank trim and plumbing products.

These dimensions are nominal and subject to change without notice.

Fixture performance and specifications meet or exceed ASME A112.19.2-2008/CSA B45.1-08 standards, and other state and local codes.-1037 standards.

Valve specifications meet ASSE-1037 standards.