

PRO-FIT® WHIRLPOOL & BATHTUB

4260 TFS 59 3/4" x 42" x 21 1/4"

Model number: 6124/6624 LH, 6125/6625 RH

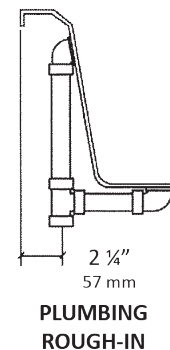
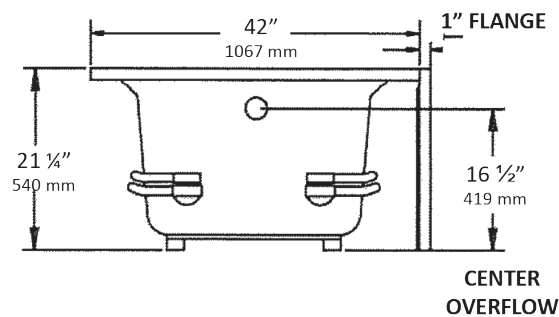
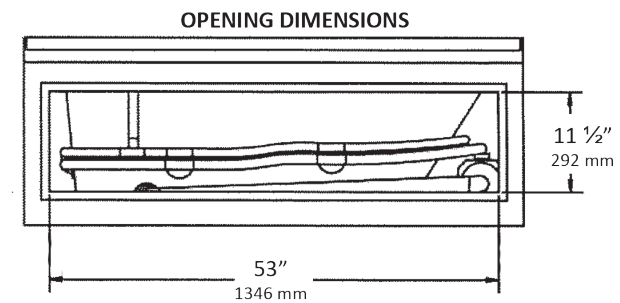
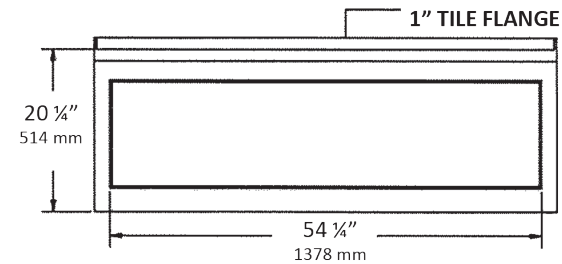
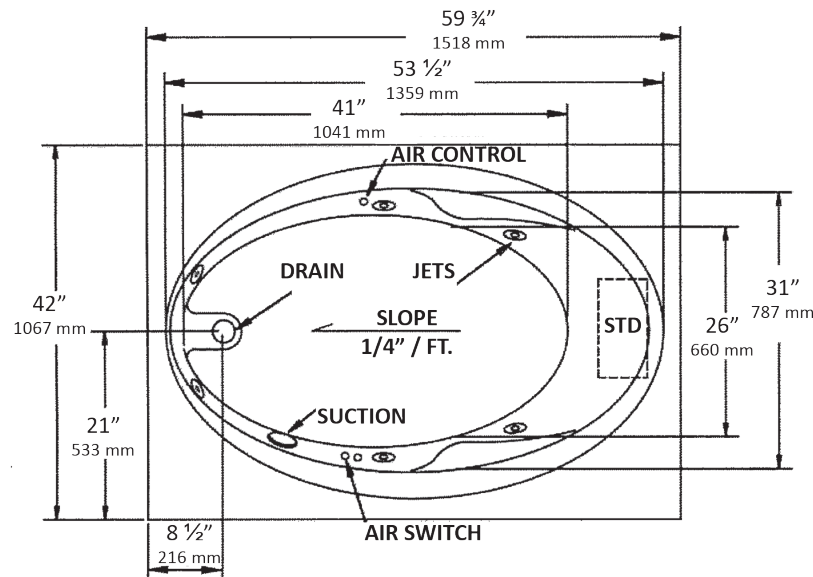

NOTES:

1. Pump location shown for clarity.
2. Required pump/motor access is 20" W x 15" H.
3. Measurements may vary 1/4" (+/-).
4. Apron is integral with optional removable access panel for access to pump/motor.
5. Due to integral tile flange, a nailing flange is not available on this unit.
6. Specify LH or RH drain when ordering.

SPECIFICATIONS:

Dimensions:	59 3/4" x 42" x 21 1/4"	Number of jets:	6
Material:	Acrylic, fiberglass reinforced	Weight:	100 lbs. (41 kg)
Pump Motor:	120 V, 60 HZ, 6.0 Amp, Single Speed, Premounted	Water Capacity:	55 gals max., 42 gals min. 160 liters/103 liters
Electrical Requirements:	120 V, 15 Amp, GFCI Protected	Floor Loading:	47 lbs./sq.ft. (229 kg/m ²)
On/Off Control:	Air Switch	Shipping Weight:	146 lbs.