

IMPORTANT HOME OWNER INFORMATION

Ariance™

Air Baths



mansfield®

SAVE THESE INSTRUCTIONS

WARNING

INSTALL TO PERMIT ACCESS FOR SERVICING.

INSTALL THIS UNIT IN ACCORDANCE WITH THE LOCAL ELECTRICAL CODE.

(Canadian electrical code, part 1, for Canada).

NOT APPLICABLE IF UNIT IS SUPPLIED WITH AN ELECTRIC PLUG.

DANGER: RISK OF ELECTRICAL SHOCK. (Consult local electrical sub code official).

Use this unit only for its intended use as described in this manual. Do not use attachments not recommended by the manufacturer. For indoor use only. Grounding is required. The unit should be installed by a qualified service representative and grounded. The unit must be connected only to a supply circuit that is protected by a ground fault circuit interrupter (GFCI ñ class A in Canada). Such a GFCI should be provided by the installer and should be tested on a routine basis. To test the GFCI, push the test button. The GFCI should interrupt power. Push the reset button. Power should be restored. If the GFCI fails to operate in this manner, there is a ground current flowing, indicating the possibility of an electric shock. Do not use this unit, and have the problem corrected by a qualified service representative before using. For permanently connected units, a green colored terminal is provided within the terminal. To reduce the risk of electric shock, connect this terminal or connector to the grounding terminal of your electric service or supply panel with a conductor equivalent in size to the circuit conductors supplying this equipment. This unit has no user serviceable parts. All service must be performed by a qualified service representative. Each accessory is supplied with its own separate operating instructions and must be read, followed and saved. Always consult local codes and/or local sub code official.

WARNING - IMPORTANT SAFETY INSTRUCTIONS

1. DO NOT allow children to use this unit without close adult supervision.
2. DO NOT drop or insert any foreign object into any opening.
3. DO NOT disconnect, alter or tamper with any electrical wiring. Service must be performed by a licensed electrician or factory authorized person. Power must be off at the source prior to any electrical work.
4. DO NOT use the air bath while under the influence of any drugs or alcohol.
5. Persons with heart problems, high blood pressure, other illnesses or pregnant women should consult a physician prior to using an air bath system.
6. To avoid injury exercise care when entering or exiting the air bath.
7. Warning: Risk of Hyperthermia and possible drowning. Do not use a Hydromassage
8. Warning: Risk of Electric Shock: Do Not permit electric appliances, such as hair dryer, lamp, telephone, radio or television within 5 ft./1.5m of this bathtub.
9. Caution: Test the Ground Fault Circuit Interrupter protecting this appliance periodically in accordance with the manufacturer's instructions.
10. Warning: Risk of Hyperthermia or possible drowning. Water temperature in excess of 38C (104°) may be injurious to your health. Check and adjust water temperature before use. Prolonged immersion in water hotter than body temperature may induce hyperthermia.

INSTALLATION GUIDE

BEFORE YOU START

Read the instructions completely prior to beginning installation.

1. Carefully inspect the unit for any damage, missing parts, breakage or scratches that may have occurred during shipping or handling. If necessary, file a claim immediately with the freight carrier.
2. Physically measure the unit and verify against the specification sheet. Specs are +/- 3/8". (Specs are subject to change without notice).
3. Water test all air bath baths before proceeding with installation. Each unit has been tested in our facility to ensure water tight seals. However, rough handling during shipping may cause leaks. Locate the air bath in an area where it can be filled and drained easily. Fill the unit with water to one (1) inch below overflow. Allow water to stand in unit for five (5) minutes and check for leaks. Operate air bath for at least fifteen (15) minutes. Check the entire system for leaks before, during and after operation.

If you have any questions, discover any damage, leaks, missing parts, etc., do not proceed with installation. Call our Customer Service Department at 800-999-1459. We will be happy to help you.

Thank you for purchasing our product and taking the time to read these instructions. For the best quality installation, we recommend you use professional carpenters, licensed plumbers and a licensed electrician.

SHIPPING PROTECTION OF THE AIR BATH

1. Mansfield provided protective materials with each Air bath product to protect the unit from damage during shipping and installation. The use of any protective material is highly recommended to prevent any unnecessary damage such as scratches, abrasions or cracks.
2. Cut-out templates are also provided for each unit. The template is included with the product packaging as a cardboard cutout or a folded paper template. Please do not discard the template until the installation has been completed.

NOTE: ANY ALTERATIONS, ADDITIONS OR DELETIONS MADE TO THE Air bath SYSTEM, BLOWER OR BATH WILL VOID THE MANSFIELD WARRANTY.

3. Literature dimensions are for general reference only. Installation dimensions should be taken directly from the bath. An **ACCESS PANEL MUST BE PROVIDED** at the blower end of the air bath allowing sufficient clearance to make final connections and for servicing the blower and power panel. Access of at least 12" x 18" (305mm x 457mm) may be through the wall or platform apron at the end of the unit, or in the case of sunken installations, through the ceiling below.
4. DO NOT USE BLOWER OR ANY PORTION OF THE PLUMBING FOR LIFTING OR POSITIONING OF TUB.
5. Install the drain fitting to the bath. THE DRAIN FITTING WILL PROTRUDE BELOW THE BASE OF THE TUB APPROXIMATELY 1". Clearance must be provided for the drain by cutting away the subfloor where possible or blocking below the tub may be required. WARNING: FACTORY APRONS DO NOT ALLOW FOR BLOCKING UP OF THE TUB BASE. All blocking must be solid and provide uniform support to bottom of tub. Bath must rest entirely and firmly on the subfloor. DO NOT SUPPORT THE WEIGHT OF THE BATH BY THE RIM.
6. When leveling is required, prepare a bed of wet mortar or plaster and install the bath ensuring the mortar or plaster provides uniform support to all areas of the base. Note: Installing the unit in plaster or mortar provides the most support. When combined with proper wall insulation, this significantly reduces the water circulation noise normally associated with air baths.
7. Frame out under the tub rim as shown in the basic installation diagrams. NOTE: DUE TO THE VARIETY OF INSTALLATIONS POSSIBLE WITH THIS BATH, FRAMING PROCEDURES OTHER THAN THOSE DESCRIBED MAY BE REQUIRED. A ledge under the rim, or an apron without a ledge, may be constructed as required. Where installation will be against a wall, stud wall framing should allow for wall sheathing material to run full length to the floor. Install tub against sheathing as indicated, with blocking below rim to prevent deflection or movement of the tub, but ensuring the tub is not supported in any way by the blocking.
8. When placing the tub in a platform or floor cutout, the opening should be 1" smaller than the specified rim dimensions. Extreme care must be taken in this type of installation to ensure the bath will come to rest entirely on the base and not on the rim.
9. Install standard 1 1/2" trap to drain and overflow. Before proceeding, make final operational check by filling tub with water to the overflow and operate blower for 15 minutes. Carefully check for leaks both while blower is activated and while the blower is turned off. Allow water to stand in bath for at least 30 minutes before draining. MANSFIELD WILL NOT BE RESPONSIBLE FOR WATER DAMAGE OF ANY KIND IN CONNECTION WITH ANY OF OUR AIR BATHS. At this point, the bath must be checked to ensure proper drainage of the bath floor.
10. Always reference faucet manufacturer's installation instructions. Install fill valves and spout in desired location. When selecting fill spout, ensure that it is long enough to clear the bath rim from its desired location on or near the bath. When installing, be sure to hold the spout in its intended location and check for proper clearance. If installation is to be on the bath, check backside of bath for adequate space for connection to water lines before drilling or cutting the bath.
11. Complete installation by trimming around bath with desired finish materials. Seal joints under bath rim and against wall with water resistant sealer.

INSTALLATION DIAGRAMS

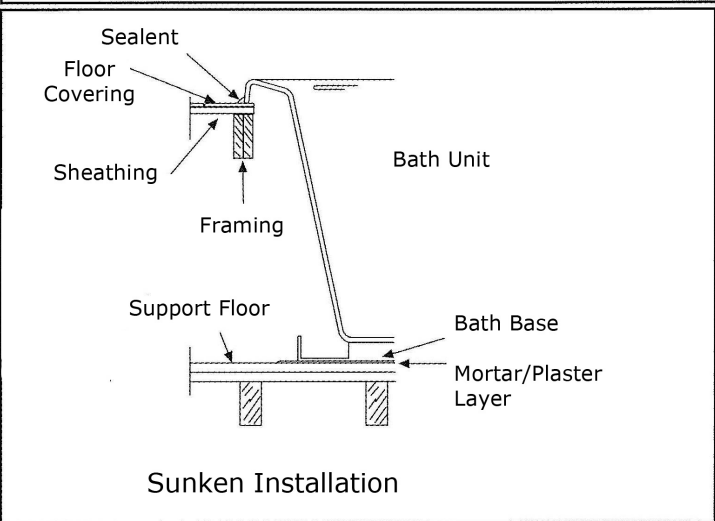
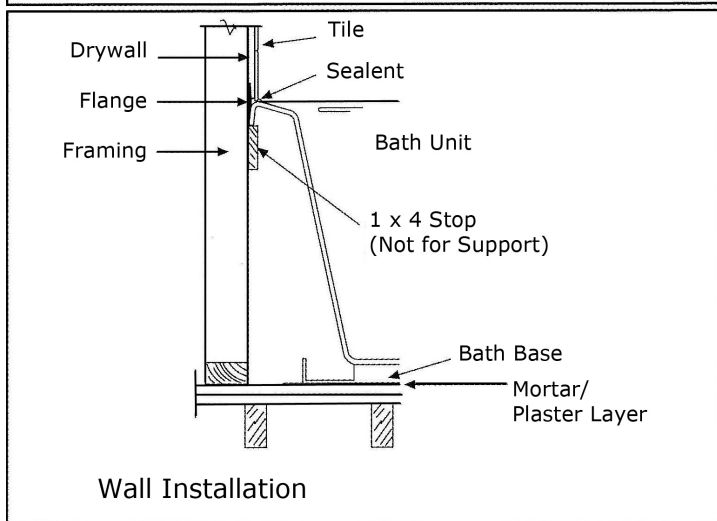
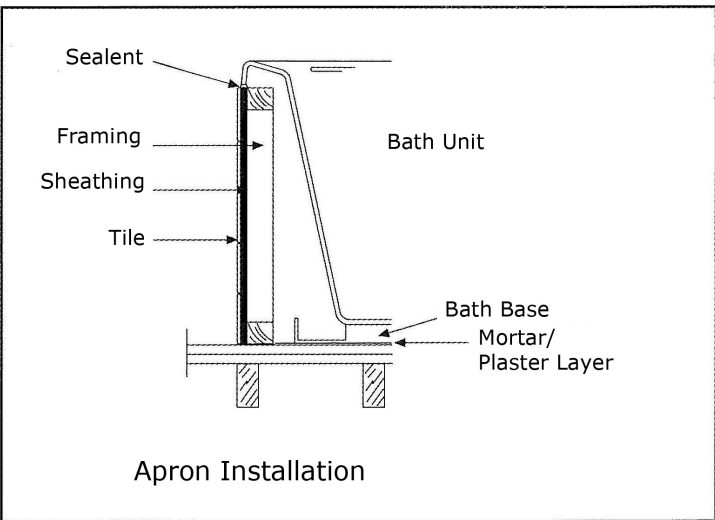
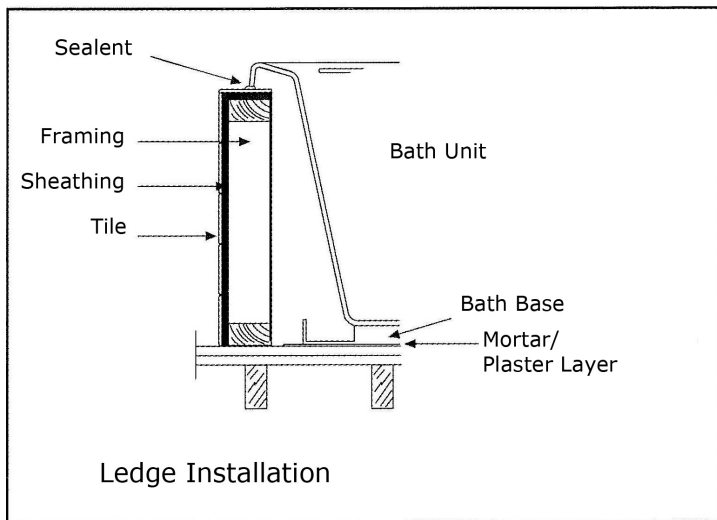

PLUMBING ROUGH-IN DIMENSIONS

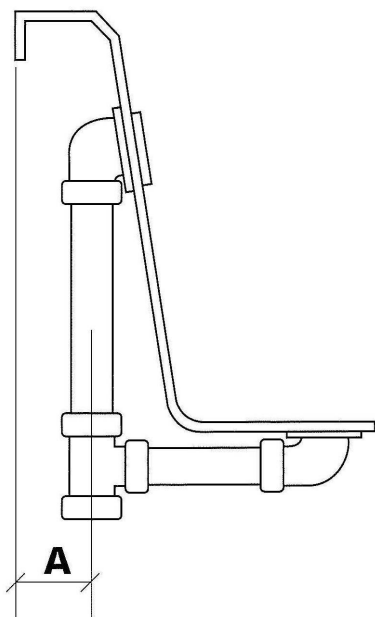

MODEL	A	MODEL	A
Allura	3"	Covington C	3 1/4"
Avalon	1 3/4"	Elba OV	1 1/2"
Barrett	2 1/2"	Elba R	1 1/2"
Barrett Alcove	3"	Enso	4"
Baywood 5.0	2 3/4"	Essence	6 1/4"
Baywood 5.5	2 1/2"	Hampton OV	4"
Baywood 6.0	2 1/2"	Hampton R	4"
Brentwood	2 1/2"	Heathrow OV	4 3/4"
Brighton	6 1/2"	Heathrow R	4 3/4"
Bristol Bay	5 1/4"	Reo	4"
Camden	2"	Savannah	3 1/2"
Castille	4 1/2"		

APRON INSTALLATION INSTRUCTIONS

INSTRUCTIONS APPLICABLE TO RECTANGULAR MODELS

Optional removable aprons are available with some models for alcove installations. **IMPORTANT:** The use of mortar or gypsum plaster mix is recommended on all installations. However, when installing a bath that requires a removable apron it is important that the bath not be raised from the subfloor more than ¼" maximum.

TRIMMING INSTRUCTIONS

1. Protect the acrylic with tape.
2. Mark off evenly on both ends the amount of apron not needed.
3. Always add approximately 1/8" to total measurement. Remember it is always better to allow for mistakes. Mark off extra and sand back to exact lines.
4. When marking line to be trimmed, be sure that the line is 90 degrees square with top horizontal detail line of apron.
5. Secure apron on table or get someone to hold the apron or panel firmly so that it does not move.
6. Cut using a jigsaw with a melamine blade or metal blade (minimum 14 teeth/inch).
7. Dress rough edges or chipped acrylic using a belt sander, angle grinder or sanding block. (60 grit paper recommended).

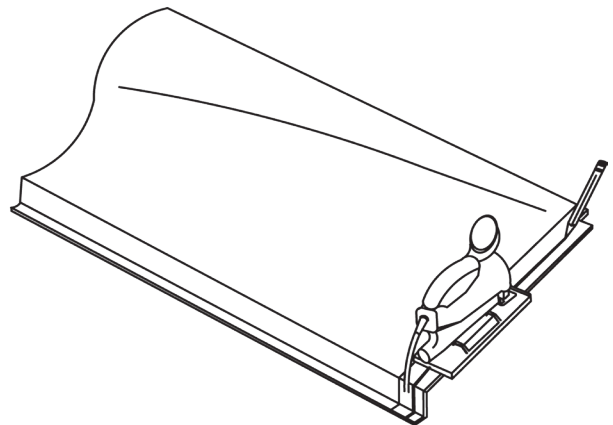
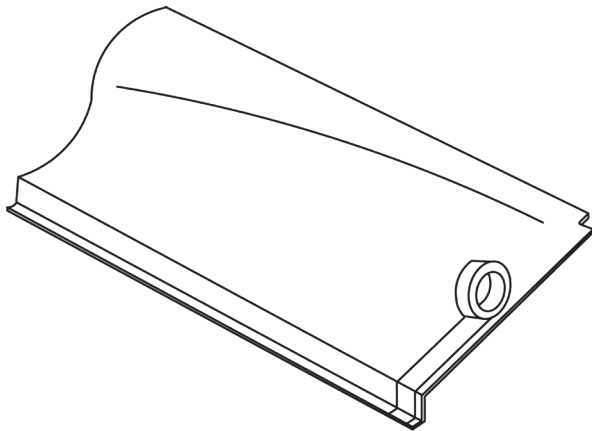

OPTIONAL NAILING FLANGE (Factory Installed)

The optional nailing flange is factory installed and secured to the tub with bonding adhesives and silicone sealers. The purpose of the nailing flange is to create a water tight seal to protect from water running behind the wall. The nailing flange may be nailed or screwed to the stud wall. This permits installing the bath next to walls.

NOTE: The Nailing flange is an optional feature and can be ordered with almost any rectangular or corner model.

An optional field installed Nailing Flange Kit is also available.

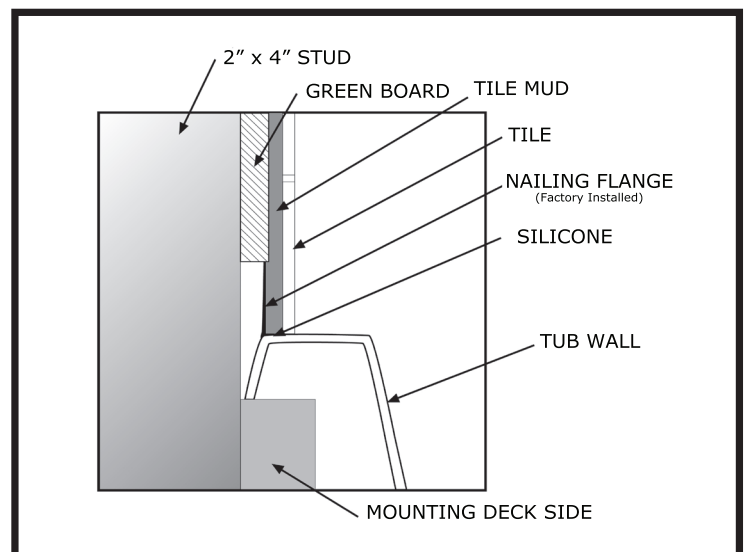

APRON INSTALLATION INSTRUCTIONS

See diagrams below for rectangular apron installation. **IMPORTANT:** Use of factory aprons requires the unit to be secured directly to the subfloor. The subfloor **MUST** be the same height as the finished floor or the apron cannot be installed. Mansfield Plumbing Products will not be financially responsible for either. After the installer has decided the exact measurement, the panel or apron should be trimmed by following the procedures on the previous page.

1. The following tools and parts will be needed for installation:

Parts:

- Six, self-tapping screws
- Three, #10 1" Stainless steel screws
- One, 1 1/2" x 1 1/2" plastic angle
- One, apron panel
- One, Toe strip with Velcro fastener

Tools needed:

- Phillips head screwdriver or power drive with attachments.
- 1/8" drill bit
- Framing square

You will also need a 2" x 2" wood strip the length of the bath.

2. If necessary, trim panel to dimensional requirements. See Trimming Instructions on previous page.
3. Locate the three wooden blocks attached to the underside of the bath deck. See Diagram 1.
4. Remove the peel-off backing from the 1 1/2" x 1 1/2" plastic angle. Note: the plastic angle should be 2" shorter than the bath length.
5. Position the angle on the wooden blocks, leaving a 1/4" gap between the angle and the bath lip. See Diagram 2.
6. Drill two 1/8" pilot holes through the plastic angle at each wooden block location. Note: Do not penetrate the wooden block more than 1/8" depth.

7. Secure the plastic angle to the wooden blocks with two #6 self-tapping screws per block.
8. Using a carpenter's square, place a mark on the floor at each end of the bath, precisely vertical with bath rim. See Diagram 3.
9. Now measure a distance of 2 1/4" inward from each mark toward the bath base. This will spot your 2" x 2" wood strip location.
10. Secure the wood strip by lagging to the floor or attaching each end to the bottom surrounding framework.
11. Before positioning, detach the toe strip from the panel by separating the Velcro fastener. Align the top edge of the panel so it is parallel with the bottom of the bath rim. Slip the panel up between the rim and the plastic angle while holding the panel at the bottom. Move it inward toward the bath and butt the toe kick against the 2" x 2" wood strip. The panel should be positioned vertically with the bath rim, and the top offset should meet the bottom of the bath rim. Installation can be assisted by cutting two 2" x 4" blocks and shimming underneath the toe space to keep the panel aligned while attaching.
12. Secure the toe space flange to the 2" x 2" wood strip by positioning the screws at the factory drilled 3/16" hole location and screwing the wood strip as shown in Diagram 4. Attach the toe strip to the flange.

Diagram 1

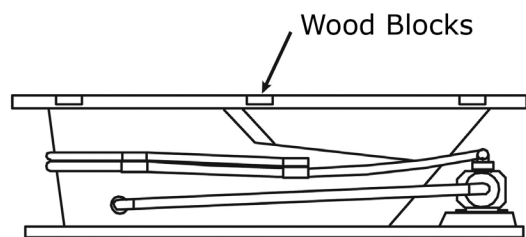

Diagram 2

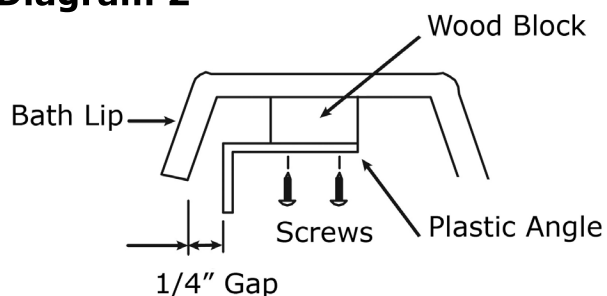

Diagram 3

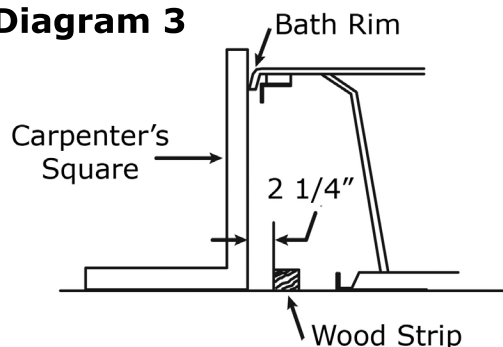
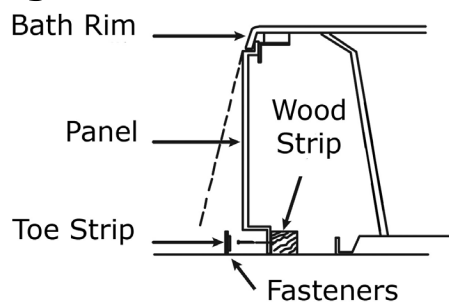

Diagram 4



REMOTE BLOWER INSTALLATION GUIDELINES

- Blower motor should be connected to a circuit that is protected by a Ground Fault Circuit Interrupter. 120V, 60HZ, 20 Amp.
- All electrical connections should be performed by a licensed electrician and in accordance with National, State and Local codes.
- The GFCI should be located at the main breaker panel.
- The blower motor and controls are factory installed according to ETL requirements. However, the blower may be relocated in a remote location for accessibility and easy access.
- For models with the heated backrest feature, remote locating the blower(s) will result in loss of heat in this area.

Remote Installation Guidelines

- Blower motor must be accessible at all times.
- Location must be unobstructed and allow for sufficient air flow.
- Blower motor area should be free from any loose debris which could be induced into the motor.
- Motor location should be within 10' of tub with few directional changes to allow the system to work efficiently.

Removal of Blower Motor

- Disconnect the motor from the tub by following these procedures (Reference Drawing 1).
- Loosen the hose clamp connecting the flexible air hose and blower discharge.
- Remove the screws that attach the motor to the tub base.
- Unplug the Blower from the control box.
- Remove the screws that attach the control box to the tub base.
- Disconnect the keypad cable from the keypad and control box.

Remote Mounting kit includes:

- 9 feet (9') Flex hose
- Two (2) Hose clamps
- 12 feet (12') Keypad cable
- Hose adapter

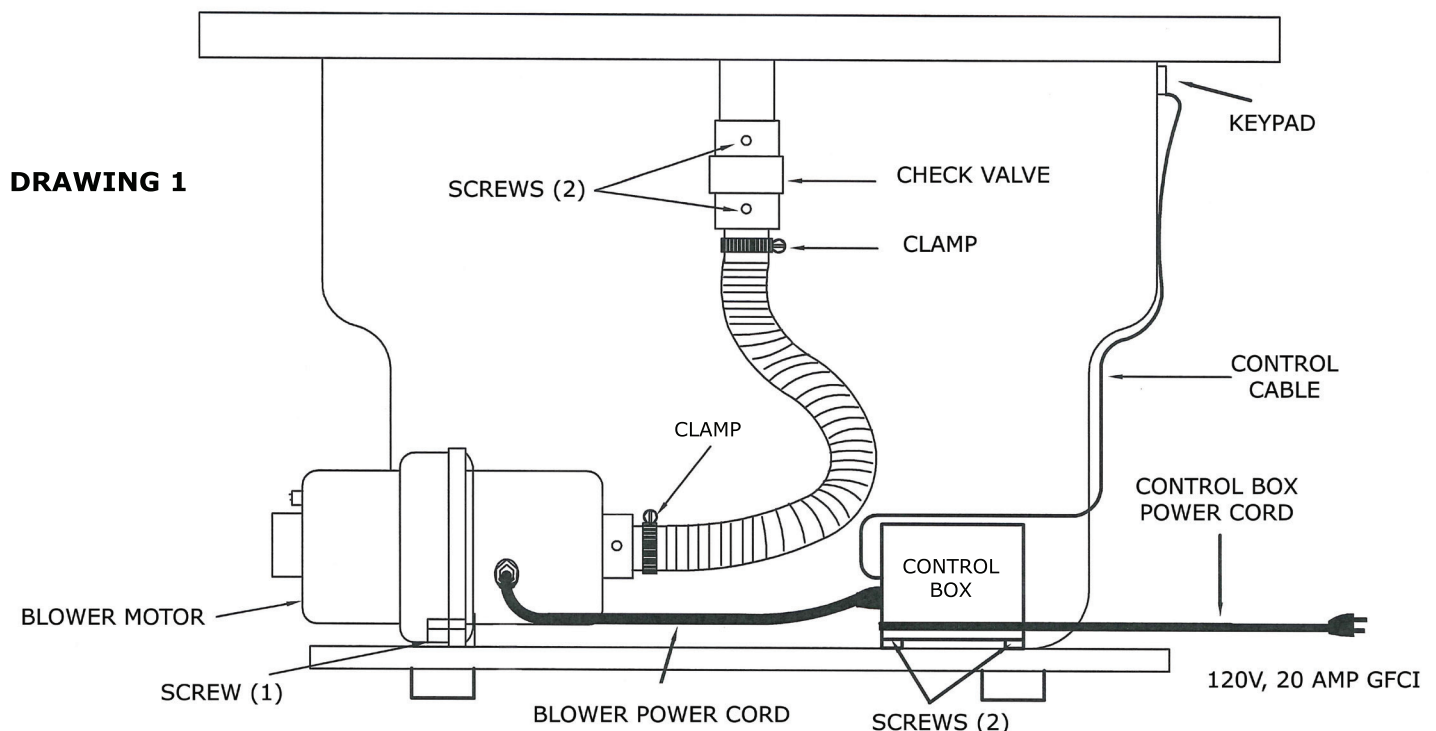

REMOTE INSTALLATION OF BLOWER MOTOR

CAUTION: USE PVC/ABS CEMENT TO MAKE CONNECTIONS. The blower motor is equipped with an internal heating element that can cause any un-evacuated cement fumes to combust. Always allow the cement fumes to evacuate before turning blower on. A waiting period of 24 hours is necessary before using the blower if pipes have been glued together.

Drawings 2 and 3

- Use 1 1/2" PVC or ABS pipe/fittings or 1 1/2" flexible hose for connecting the blower to the intake port of the bath. The blower can be mounted vertically or horizontally, but must be positioned for optimum airflow in the intake.
- The control cable connecting the blower and the control keypad is delivered with a 12 ft. cord. Always consider the distance between the two components before making final cutouts or attachments.
- The blower motor should always be mounted a minimal of 6" from the floor level when mounting in adjacent locations. When mounting the blower underneath the floor of the bath, install it as high as possible.
- Do not tamper with, remove or relocate the check valve.
- Use two 45 degree elbows in place of 90 degree elbows whenever possible to allow for sufficient airflow with less restriction.

DRAWING 2

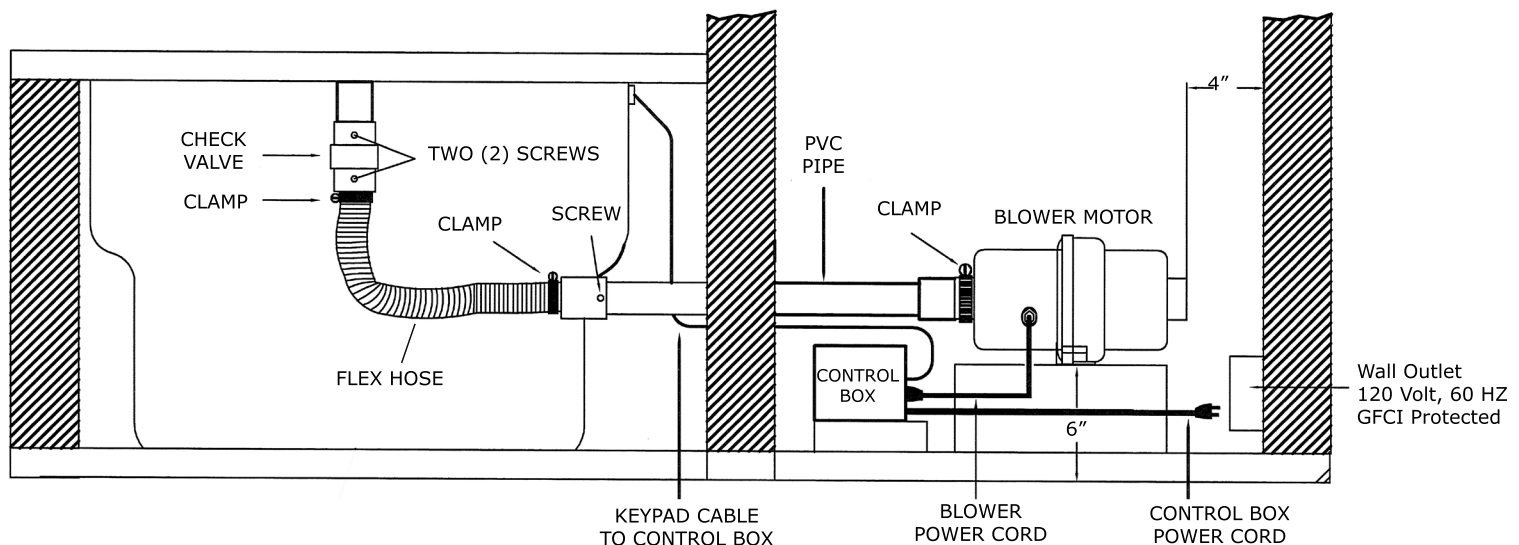
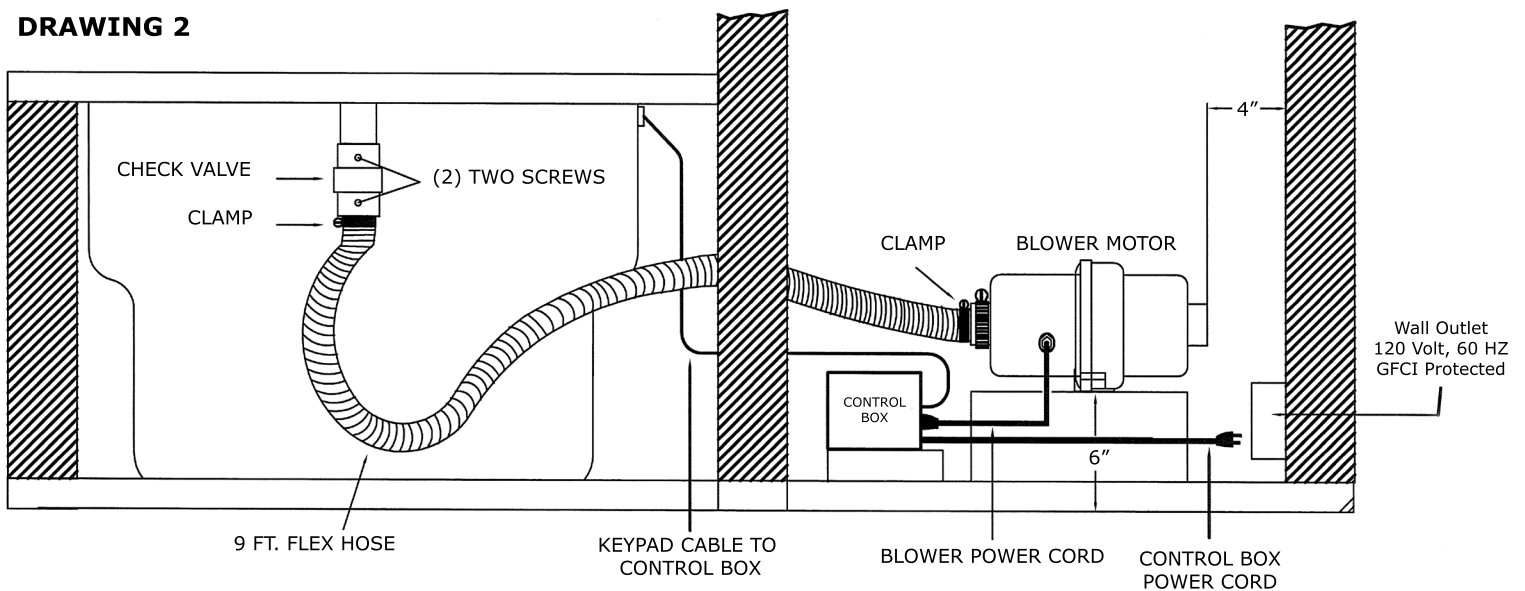

ELECTRICAL INSTRUCTIONS AND WIRING DIAGRAMS

WARNING: ALL ELECTRICAL CONNECTIONS SHOULD BE MADE BY A LICENSED, LOCALLY CERTIFIED ELECTRICIAN, IN ACCORDANCE WITH THE REQUIREMENTS OF THE NATIONAL ELECTRIC CODE AS WELL AS APPLICABLE STATE AND LOCAL CODES AND PROCEDURES. WARNING: RISK OF ELECTROCUTION.

1. All air baths must be connected to a circuit that is protected by a Ground Fault Circuit Interrupter. 120 V, 60 HZ, 20 AMP located at the main fuse box.
2. Use a 12 gauge three conductor cable (2 wires plus ground) in connections up to 100 feet from the main fuse box.
3. When installing air massage baths, make sure that a Ground Fault Circuit Interrupter is installed on an INDEPENDENT CIRCUIT for each blower required. 2 circuits maximum.
4. All Ariance air baths are factory supplied with a pre-wired cord and plug. Wall outlet(s) must be installed within thirty (30) inches of blower location.
5. The electrical installation is subject to inspection and approval by local authorities.

Health Touch™ and Gentle Touch™ Wiring Diagram

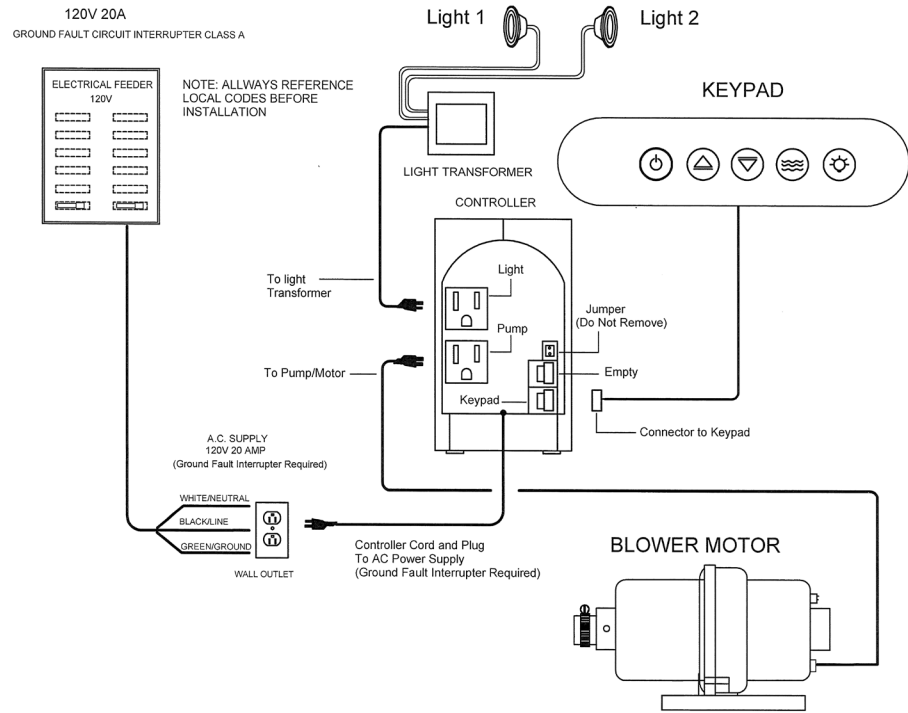

Dual Therapy™ Wiring Diagram

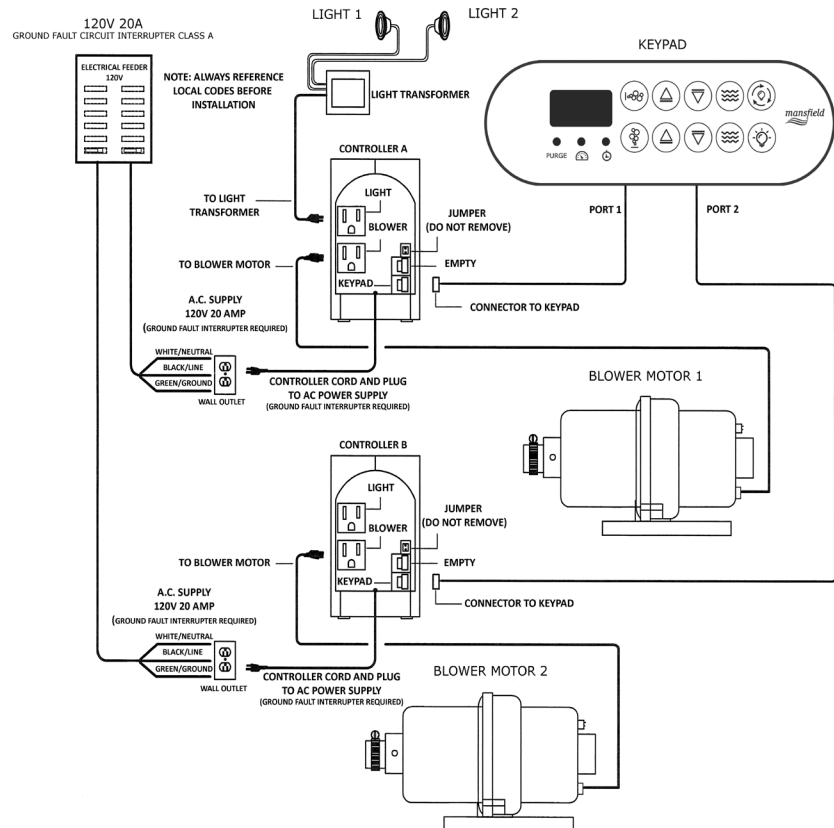

OPERATING INSTRUCTIONS

BEFORE OPERATING THE AIR BATH, FILL THE BATH TO NORMAL BATHING LEVEL (MINIMAL 3" BELOW OVERFLOW).

Health Touch™ and Gentle Touch™ Systems

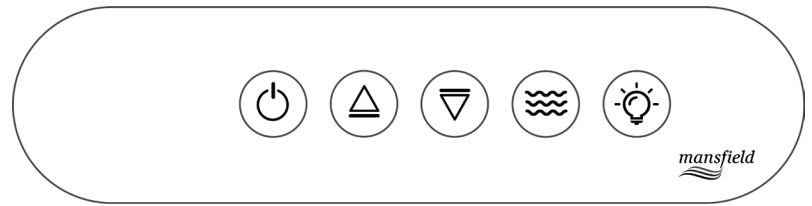

Your Ariance Health or Gentle Touch System air bath has a five button keypad.

The first button is the Power button. With the 1st press, you will turn the blower motor ON. The blower motor speed is softly ramped up to the maximum speed of 10 and then the speed will return to the last speed selected during the previous use of the air bath. Also with the 1st press, the Chromatherapy Mood Light System will be activated. To turn off or change the Mood Light, press button five.

The second button is the speed up button. Press the second button repeatedly to increase the blower motor speed. The maximum speed is 10.

The third button is the speed down button. Press the third button repeatedly to decrease the blower motor speed. The minimum speed is 1.

The fourth button is the wave and pulse mode. With the 1st press, you will activate the wave and pulse mode. The blower motor speed will increase and decrease over a few seconds time and continue during the remaining 20 minute cycle.

The fifth button is the Chromatherapy Mood Light System button. The 1st press will turn on the Mood Light. Press the button repeatedly to change the color of the Mood Light and to activate the light shows. Continue pressing the button until the light turns off.

Dual Therapy™ System

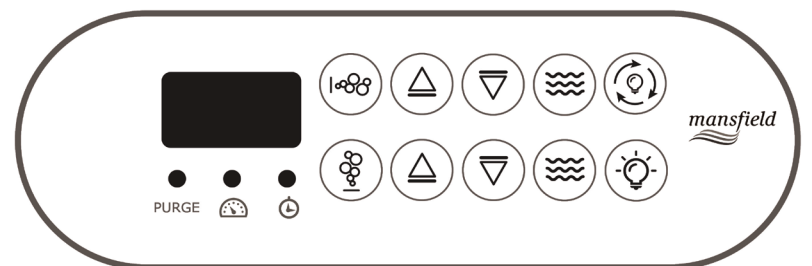

Your Ariance Dual Therapy System air bath has a ten button keypad.

The operation is the same as the Health and Gentle Touch Systems above, with a few exceptions. The top row of buttons controls the Health Touch, or channel system. The bottom row controls the Gentle Touch, or air injector system. The systems can be operated independently or simultaneously.

The first four buttons on each row operate the same as described above.

The fifth button on each row operates differently. When the power to the system is turned on, the Chromatherapy Mood Light System is activated as indicated by the light on the fifth button on the bottom row. To change the color of the Mood light, press the light cycle button, which is the fifth button on the top row. With each press, the light will briefly pause and then change colors or the light show will begin. Stop pressing the button when the desired color is reached. To turn it off, either power off the system, or push the fifth button on the bottom row.

MAINTENANCE, CLEANING AND REPAIRS

Your Ariance® air bath is made of cast acrylic. Cast acrylic provides a beautiful, high-gloss finish that is extremely durable and is a beautiful look in any bathroom.

IMPORTANT! Use the recommended information described in this section. Use of other cleaning materials and/or methods may harm your air bath and will void your warranty. The air bath surface will retain its color and glass indefinitely with normal use, but some bathroom cleaning agents will cause harm. Failure to perform periodic maintenance on your air bath may cause health and/or safety problems as well as possibly harming the bathtub, blower or piping thus voiding all warranties.

Surface Repair

If an accident occurs and your air bath has a scratch or minor abrasion, it can be repaired by buffing. If the damage is superficial, use a polishing compound used for automobile finishes. If the damage is a little deeper, sanding the spot before applying the polish will normally take care of the problem. The depth of the scratch or abrasion will determine the sandpaper grade to use. A 600 grade paper is required for light to moderate damage and 400 to 220 grade will be needed for deeper damage. When sanding, begin with the lowest number grade of paper and work up to using the auto car polish. With a change of paper, you will need to sand a slightly larger area than the damaged area.

It is not recommended that you repair heavy damages or damage in the bottom of the bath yourself. We will be happy in assisting you in finding a qualified acrylic repair company.

CLEANING

Because of the detrimental effects that mineral deposits, soap scum and hard water stains have on finished surfaces, it is important to keep your bathtub and the fixtures of your Ariance air bath clean on a regular basis.

1. Once a week, wash all exposed surfaces of the bathtub with a mild solution of vinegar and water. Check for stubborn spots. Oily or greasy spots can be lifted with denatured alcohol. Wipe off with clear, warm water and dry with soft cloth.

WARNING: Under no circumstances should wire brushes, metal sponges, knives, steel wool or scouring pads be used on any part of the bath, nor petroleum based solvents such as paint thinner, acetone or abrasive cleaners. All of the afore mentioned products and the like will damage the finish of the bathtub.

2. Twice per month or more, depending on usage, purge and clean the entire air bath system following the directions below.
 - a. Fill the air bath with hot water.
 - b. Add Two (2) tablespoons of low sudsing automatic dishwasher detergent and ½ cup of household bleach to the water.
 - c. Run air bath for at least 15 minutes.
 - d. Drain, refill with cold water and operate for 10 minutes. Drain again. The system will run the purge cycle twenty minutes after the blower has been turned off and run for approximately two minutes. Wipe with a damp cloth.

CODE COMPLIANCE



Accepted by the "Swimming Pool Research Committee" of the International Association of Plumbing and Mechanical Officials as meeting the requirements of the Uniform Swimming Pool Code. (For Air bath Piping). Listed SP-1179



Accepted by the "Plumbing Research Committee" of the International Association of Plumbing and Mechanical Officials as meeting the requirements of the Uniform Plumbing Code. (For Acrylic Bath Shells). Listed 2719



ETL Listed (Complies with U.L. Standard 1795). Hydromassage Bathtub Listed 3129295

WARRANTY

Mansfield Plumbing Products
Bathware –Ariance® Brand Air Massage Baths

Residential Warranty

Mansfield Plumbing Products, LLC offers the following expressed warranty to the original purchaser of any Ariance Air massage bath who purchases the product for personal or single family residential use (“user”). We will repair or replace, at our sole option, the product or its equipment in accordance with the following terms and conditions.

TEN (10) YEAR WARRANTY FOR ACRYLIC SHELL

Mansfield Plumbing Products, LLC extends to the user of the product a non-transferable Ten (10) year warranty from the date the product was originally purchased by the user that the shell will maintain its structural integrity and be free of water loss due to a defect in the tub shell. This warranty covers only the product shell against defects in material or workmanship.

FIVE (5) YEAR LABOR WARRANTY FOR ALL FACTORY INSTALLED COMPONENTS

Our limited labor warranty is for a period of Five (5) Years from the date the product was originally purchased by the user, but not more than Six (6) years from the date of manufacture. All factory installed components (e.g., blower, jets and plumbing) are covered under our labor warranty against failure due to defects in materials and workmanship.

WARRANTY LIMITATIONS

In no event shall Mansfield Plumbing Products LLC be liable for incidental or consequential damages, for damages resulting from improper installation or for damages caused by handling, neglect, abuse or alteration. Our warranty does not cover defects or damage caused by the common carrier, installer, user or other persons resulting from, without limitation: careless handling, improper voltage supply/electrical modifications, misuse; incorrect operation; lack of or improper routine maintenance; incorrect or inadequate water use or use of improper cleaners. Chips, cracks and scratches are damages and are not covered under warranty; however, they may be repaired by a qualified technician at the user’s expense. Damages or defects that should have been detected before installation are not covered. All implied warranties, including any warranty of fitness for any particular purpose of merchantability, or those that might arise from a course of dealing with the purchaser or usages of trade, are hereby disclaimed or excluded.

Mansfield Plumbing Products LLC is not responsible or liable for any delays or any failure to perform due to unforeseen circumstances or causes beyond Mansfield Plumbing Products LLC’s control, when such delays or failure is due, directly or indirectly, to acts of God, war (including civil war), riots, embargoes, acts (whether sovereign or contractual) of civil or military authorities, acts of any government, major change in economic conditions, fires, floods, explosions, the elements, epidemics quarantine restrictions, strikes, lockouts, plant shutdowns, slowdowns, accidents, shortages of raw energy, materials, component parts, labor, or delays of suppliers or subcontractors.

Note: Some states do not allow limitations on an implied warranty, and some states do not allow exclusions or limitations regarding incidental or consequential damages, so the above limitations may not apply to you. This warranty gives you specific legal rights and you may have other rights which vary from state to state. No person is authorized to change, add to, or create any warranty or obligation other than set forth herein. This is our exclusive warranty.

RESPONSIBILITIES OF OTHERS

Inspecting the unit prior to installation is the responsibility of the installer or building contractor who acts on behalf of the user. They are responsible for ensuring the unit is free of defect or damage. Notices are placed on and in the unit and on the shipping carton advising the installer of this responsibility. In the event of a problem, the unit must not be installed. The Company is not responsible for failures or damage that could have been discovered, repaired, or avoided by proper inspection and testing (including proper water testing) prior to installation.

Damage occurring in transit is the responsibility of the carrier. The user or installer MUST open the crate and inspect the unit for damage when it is delivered. If damage is discovered, it must be reported immediately to the seller and the carrier in writing, and an inspection requested. Failure of the carrier to respond should be reported to the seller and the carrier. Your freight claims should be filed promptly thereafter.

It is the responsibility of the installer, building contractor, or user to provide access for service. Mansfield Plumbing Products, LLC is not responsible for any costs relating to obtaining access for repair.

WARRANTY SERVICE

Mansfield Plumbing Products, LLC maintains a list of independent service personnel to perform required warranty service repairs. Such firms are not agents or representatives of Mansfield Plumbing Products, LLC and cannot bind us by words or conduct. We will provide warranty service when Mansfield Plumbing Products, LLC has been notified of the problem during the active warranty period and deemed the problem to be of the nature or type covered by the warranty.

The product serial number, users address and contact information must be provided to obtain warranty service.



SERIAL NUMBER